

WILLARD CUTTER-BENDER

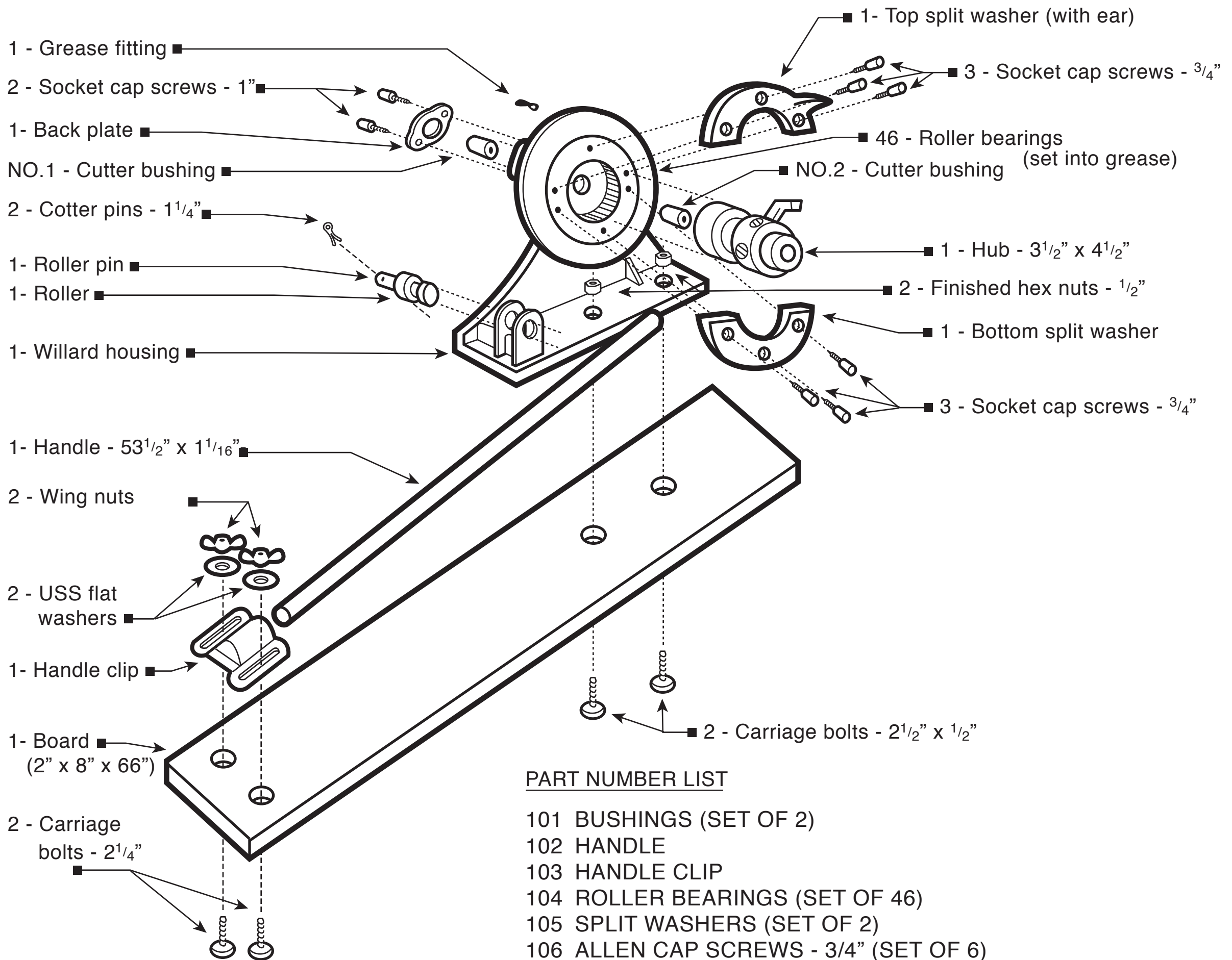

PART NUMBER LIST

- 101 BUSHINGS (SET OF 2)
- 102 HANDLE
- 103 HANDLE CLIP
- 104 ROLLER BEARINGS (SET OF 46)
- 105 SPLIT WASHERS (SET OF 2)
- 106 ALLEN CAP SCREWS - 3/4" (SET OF 6)
- 107 STEEL HUB - W/ CUTTER INSTALLED
- 108 ROLLER
- 109 ROLLER PIN
- 110 HOUSING
- 111 BACK PLATE
- 112 ALLEN CAP SCREWS - 1" (SET OF 2)
- 113 GREASE FITTING
- 114 WING NUTS & BOLTS (SET OF 2 EA.)